



PHRF Rating Application Form

Owner's Name	Boat Vendor/Model
Address	Sail Number
	Yacht Name
Phone No.	Rig (Standard, Tall)

YACHT DATA AND MEASUREMENT (IN DECIMAL FEET)

I	PY	Spinnaker Girth
J	EY	Spinnaker Leach
P	LOA - Length Overall	Spinnaker Pole
E	LWL - Length at Waterline	Draft
LP (Largest Headsial)	Beam	Displacement

VARIABLES

RIG	KEEL	RUDDER	ENGINE	PROP INSTALL	PROP TYPE
<input type="checkbox"/> Masthead	<input type="checkbox"/> Fin <input type="checkbox"/> Wing	<input type="checkbox"/> Attached	<input type="checkbox"/> Inboard	<input type="checkbox"/> In Aperture	<input type="checkbox"/> Folding
<input type="checkbox"/> Fractional	<input type="checkbox"/> Full	<input type="checkbox"/> Skeg	<input type="checkbox"/> Outboard	<input type="checkbox"/> Exposed Shaft	<input type="checkbox"/> Feathering
<input type="checkbox"/> Roller Furled Jib	<input type="checkbox"/> Center Board	<input type="checkbox"/> Spade	<input type="checkbox"/> None	<input type="checkbox"/> Strut Drive	<input type="checkbox"/> Solid 2-blade
<input type="checkbox"/> Dacron Main&Jib	<input type="checkbox"/> Drop	<input type="checkbox"/> Outboard			<input type="checkbox"/> Solid 3-blade
<input type="checkbox"/> Other					

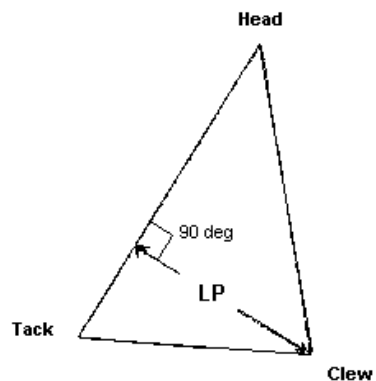
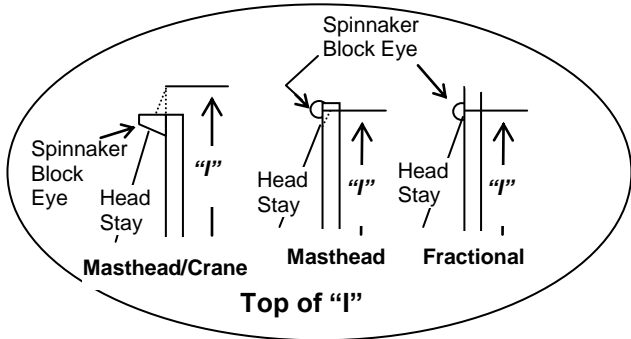
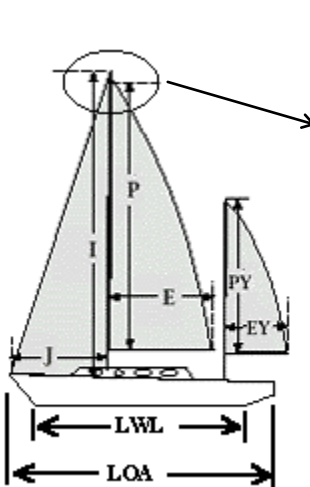

\$10 RATING FEE, payable to ECSA, deliver to ECSA PHRF Rating Chairman, Del Wiese
 520 Eleuthera Lane
 Indian Harbour Beach, FL 32937
 Phone 321-773-4884
 email dwiese@cfl.rr.com

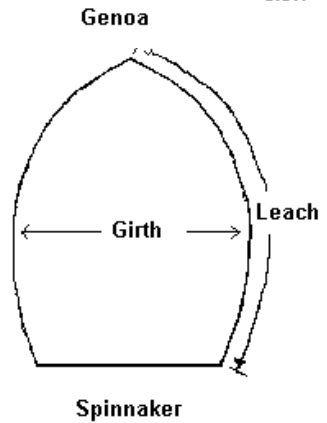

I hereby grant permission to the Measurer duly appointed under ECSA Bylaws to measure and/or inspect my boat in my presence if deemed necessary by the Rating Committee.

OWNER'S SIGNATURE: _____ Date: _____
 (you must also sign and attach the 'Liability Waiver' on Page 2)



East Coast Sailing Association
P.O. Box 372054 Satellite Beach, FL 32937-0054



PHRF Rating Application Form

LIABILITY WAIVER

I recognize that the ECSA RATING COMMITTEE's sole purpose in issuing a PHRF Handicap for my boat is to estimate the relative speed between boats and assign Handicaps accordingly.

I understand that the assignment of a Handicap for my boat by the Rating Committee does not in any way constitute a representation or warranty by the Rating Committee that my boat is designed, rigged, equipped, maintained, crewed, or operated in a manner that is safe and seaworthy for the races that I may enter using this Handicap. I acknowledge and agree that it is my sole responsibility for the safety of my boat and crew in the wind, sea, and other environmental circumstances encountered while using the boat.

In consideration of my being granted a rating by the ECSA Rating Committee, and recognizing that the Rating Committee may not have the opportunity to either measure or inspect boats prior to issuing handicaps, I hereby affirm that I have examined all of the available information relating to the design and equipment of my boat and certify that it is seaworthy and meets all other requirements of the ECSA 'General Racing Rules' and 'Safety Equipment Recommendations'. In the event that I have not examined the available information on my boat, equipment and maintenance and am unable to make the above affirmation, I hereby waive any right I may have for myself, my heirs and assigns, now or in the future to assert that the Rating Committee has assumed any obligations to assure that my boat, equipment or maintenance meets the above requirements. I, my heirs, successors, and assigns hereby hold harmless the ECSA Rating Committee members from any liability or responsibility which may flow from or be caused by any defect in design, equipment or use of my boat while being sailed by me or others.

Signature _____ Date _____